

# OPERATING INSTRUCTIONS

## GENERAL INFORMATION:

The **FasCal/FasMate** is designed to provide a safe, reliable leak-tight seal and connection when properly maintained and used. A flat, smooth, sealing surface perpendicular to the connector axis is required around the female test port. Verify the connector seal mates well with the sealing surface. Improper mating with a test piece can result in poor sealing, leakage and risk of connector failure resulting in damage or injury.

## MAINTENANCE:

User must establish a regular interval for maintenance as determined by the user media and operational environment.

Periodically inspect the **FasCal** and its seal for wear, damage and proper operation. Inspect also for lubrication needs or corrosion. Repair or replace as required to assure proper sealing, function, and safety.

Difficulty of operation indicates a need for inspection, lubrication, repair or other maintenance.

### WARNING



Use only factory authorized replacement seals and parts. Use of unauthorized parts/seals can cause failure resulting in damage or injury.

Parts and instructions available through **FasTest** or your **FasTest** distributor.

NOTE: Any field modification of **FasTest** connectors voids Factory warranty.

## FasTest, Inc. Product Warranty

FasTest, Inc. warrants its products against defects of workmanship and/or material for 12 months from the date of the sale by FasTest, Inc. This warranty is void if the product is misused, tampered with or used in a manner that is not in accordance with FasTest, Inc. recommendations and/or instructions. FasTest, Inc. is not liable for consequential or other damages including, but not limited to, loss, damage, personal injury, or any other expense directly or indirectly arising from the use of or inability to use its products either separately or in combination with other products. ALL OTHER WARRANTIES EXPRESSED OR IMPLIED, WHETHER ORAL OR WRITTEN, INCLUDING BUT NOT LIMITED TO WARRANTIES OR MERCHANTABILITY OR FITNESS FOR A PARTICULAR PURPOSE ARE EXPRESSLY EXCLUDED.

Remedy under this warranty is limited to replacement of the product or an account credit in the amount of the original selling price, at the option of FasTest, Inc. All allegedly defective products must be returned prepaid transportation to FasTest, Inc. along with information describing the products performance, unless disposition in the field is authorized in writing by FasTest, Inc.

## **FasCal/FasMate Series**

**Description: Lever, Pneumatic & Thumb Valve operated Connectors for Female Threads.**

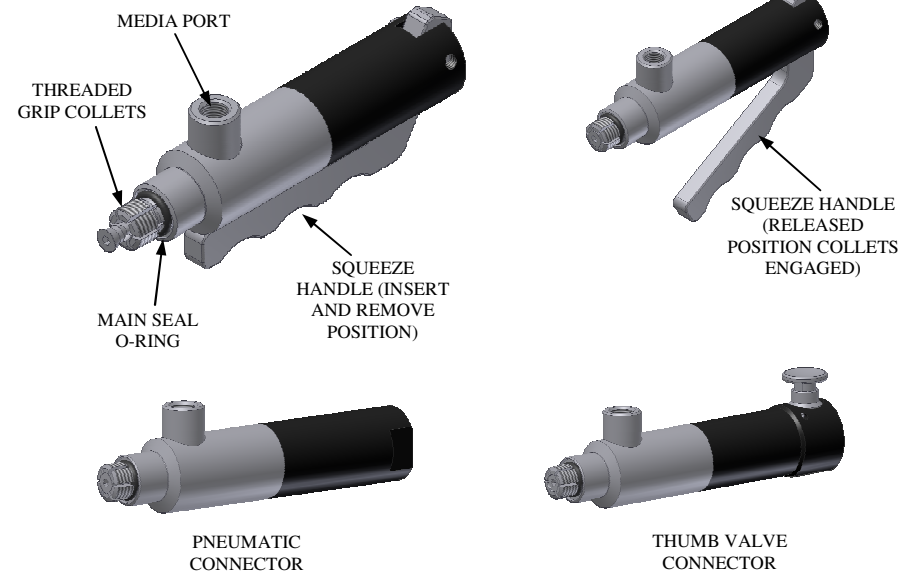

**FasCal/FasMate** Connector provides a reliable leak-tight connection that grips and seals into female threads.

Please thoroughly read and understand these operating instructions prior to operating connector. The use of pressurized media for sealing and testing requires a thorough understanding of the **FasTest FasCal/FasMate** Operating Instructions.

- Operation
- General Information
- Maintenance
- Warranty

# OPERATING INSTRUCTIONS

## OPERATION:

1. Squeeze the handle and insert the gripping collets of the **FasCal** connector into the female test port threads until the main seal o-ring contacts the component to be tested.

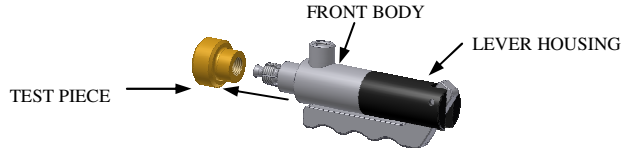

**NOTE: LEVER HOUSING POSITION CAN BE ADJUSTED BY NO MORE THAN ONE TURN (UNTHREADED) BACK FROM TIGHT AGAINST FRONT BODY.**

2. Release the handle of the **FasCal**, expanding the collets to grip the test port threads.

- Threaded collets lock into female threaded port, drawing in the sealing o-ring creating a leak tight seal for pressure testing, evacuation, charging or filling operations.

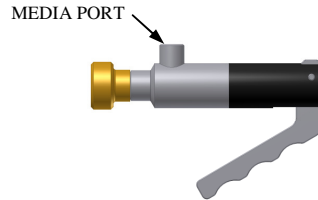

3. Introduce test media through media port for the duration of test. See chart below for media port, fitting, torque specifications. Thread sealant must be used. Also charted below are side load ratings.

Note: The torque limit is typically achieved 2-3 turns past finger tight of the fitting.

Media Port Size (NPT/BSPP)	Media Port Torque Limit (lbf-ft)
1/8	12
1/4	21
3/8	28
1/2	35
3/4	46
1	90

4. When test is complete relieve test pressure and squeeze the handle to disengage threaded grip collets from test piece.

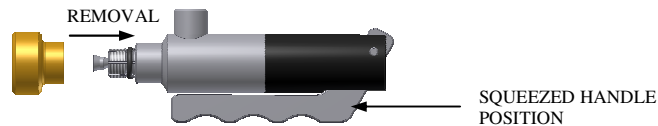

5. The previous four steps of connecting also apply to the operation of the Pneumatic and Thumb Valve operated connectors.

6. Both the Pneumatic and Thumb Valve connector require 80-120 psi. Both operators have 1/8" NPT pilot ports.

7. **Pneumatic Valve Connector:** This requires external control provided by the user to engage and disengage the collets pneumatically.

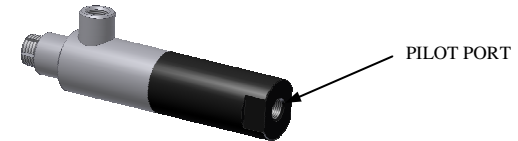

8. The Thumb Valve connector controls collet engagement by pressing the Thumb Valve on connector.

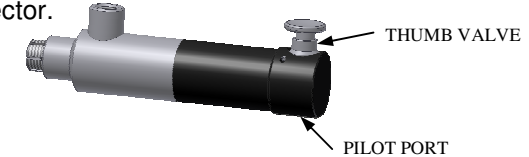

## Side Load Ratings (lbf-in) (#)=L, P or V

FN(#) Standard Insertion	FN(#)R Reduced Insertion
BS1 = 12.5 lbf-in	BS1 = 9.38 lbf-in
BS2 = 25 lbf-in	BS2 = 18.75 lbf-in
BS3 = 37.5 lbf-in	BS3 = 23.13 lbf-in
BS4 = 50 lbf-in	N/A
BS5 = 75 lbf-in	N/A

## WARNING:

- **FasTest** Connectors are designed ONLY for the threads meeting the specifications listed in the **FasTest** literature. DO NOT use in other threads.
- Connectors are NOT designed for permanent connections and are for temporary connections only.
- DO NOT EXCEED pressure rating as marked on connector.
- Verify proper connection BEFORE pressurizing. Use only in a safe environment. Safety chains and guards are recommended for all applications.
- DO NOT move connector while under pressure. Damage or injury may result.